

Quick Start Guide

BioFace B1 Series

Version: 1.0

1 Overview

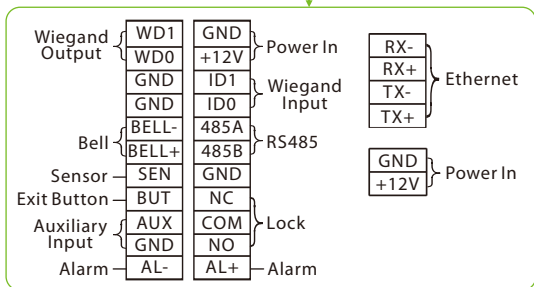
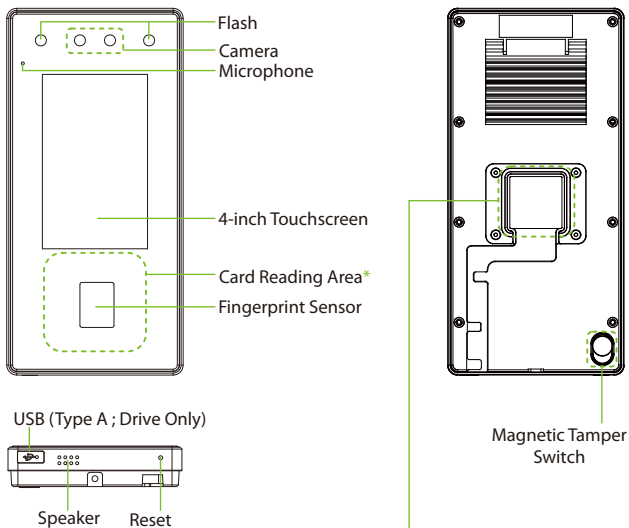

Note:

- To ensure the accuracy of fingerprint recognition, please remove the fingerprint sensor protective film before using your fingerprint.
- Not all products have the function with *, the real product shall prevail.

2 Installation Environment

Please refer to the following recommendations for installation:



INSTALL INDOORS ONLY



AVOID INSTALLATION NEAR GLASS WINDOWS



AVOID DIRECT SUNLIGHT AND EXPOSURE



AVOID USE OF ANY HEAT SOURCE NEAR THE DEVICE

- Avoid direct contact to sunlight for a long time.
- Protect the device from moisture, water, and rain.
- Handle the device with care.
- Make sure that the device is not installed in close proximity to a sea or other environments where metal oxidation and rust may occur if the device is exposed for a long time.
- Protect the device from lightning.
- Make sure that the device is not working in an acidic or alkaline environment for a long time.

3 Standalone Installation

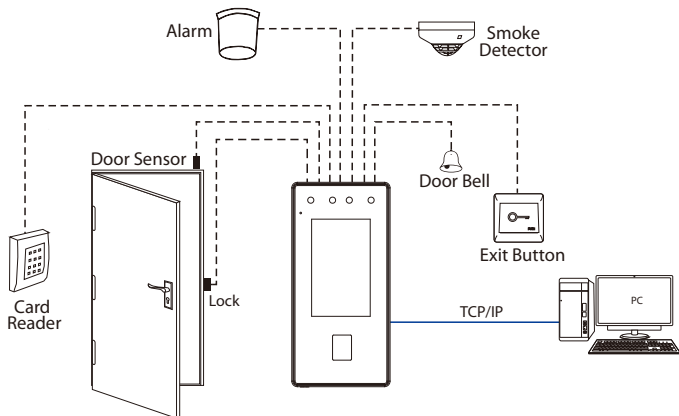

4 Door Bell, Exit Button and Alarm Connection

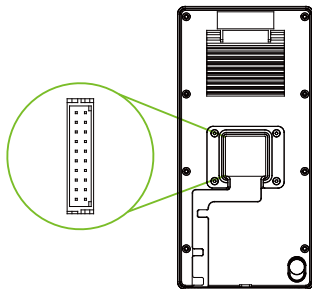
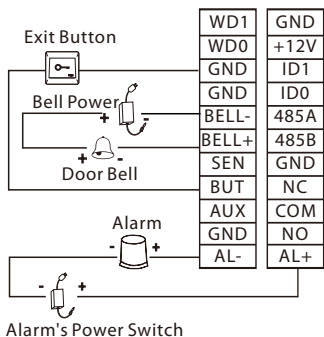

5 Door Sensor and Smoke Detection Connection

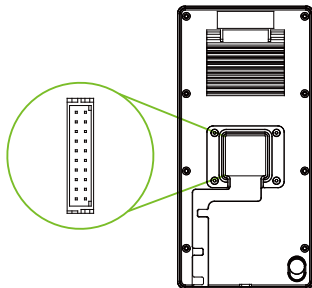
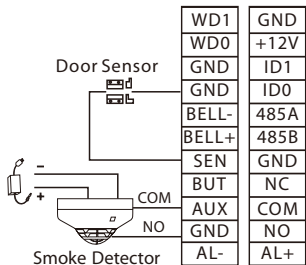

6 Power Connection

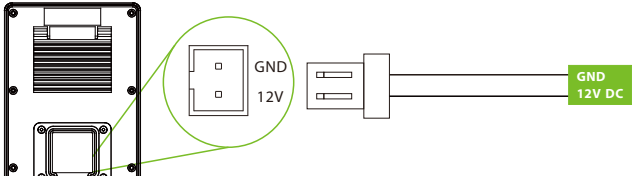

Recommended Power Supply:

- 12V \pm 10%, at least 3000mA.
- To share power with other devices, use a power supply with higher current ratings.

7 RS485 and Wiegand Connection

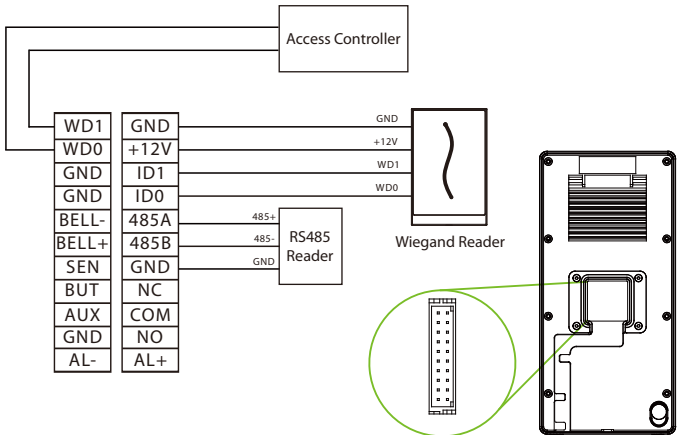

8 Ethernet Connection

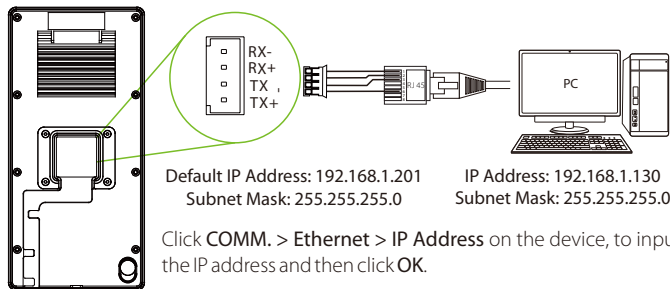

9 Lock Relay Connection

The system supports Normally Opened Lock and Normally Closed Lock.

The NO LOCK (Normally opened at Power On) is connected with "NO1" and "COM" terminals, and the NC LOCK (Normally closed at Power On) is connected with "NC1" and "COM" terminals. Take NC Lock as an example below:

Device not sharing power with the lock:

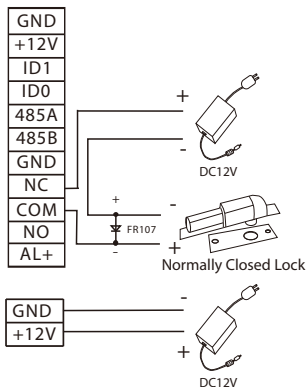

Device sharing power with the lock:

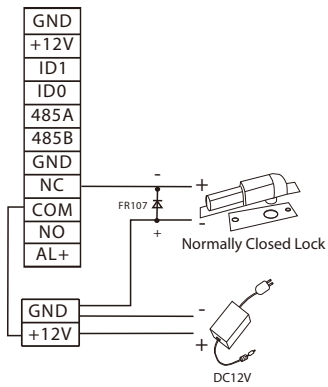

10 User Registration

When there is no super administrator set in the device, click on ☰ to enter the menu. Add a new user, set their User Role to Super Admin, and the system will request administrator verification before granting access to the menu. It is strongly recommended to register a super administrator initially for security purposes.

Method 1: Register on the Device

Click on ☰ > **User Mgt.** > **New User** to register a new user. The options include entering the User ID and Name, Setting User Role, Registering Fingerprint, Face, Card Number*, Password and Adding Profile Photo.

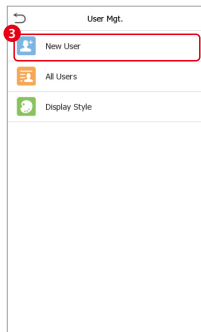
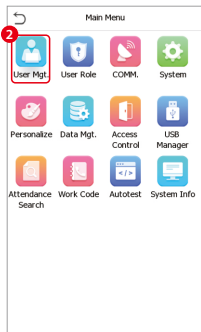
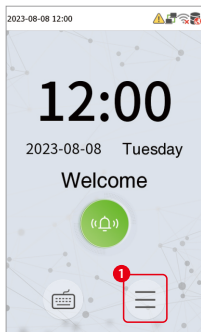

New User	
User ID	2
Name	
User Role	Normal User
Fingerprint	0
Face	0
Card	0
Password	
Profile Photo	0
Access Control Role	

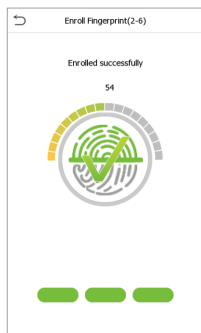
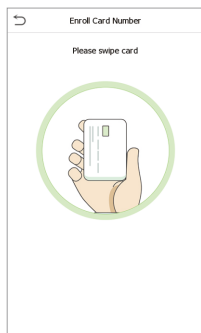

Method 2: Register on ZKBio CVAccess Software

● Register on the PC

Please set the IP address and cloud service server address, in the Comm. Menu option on the device.

1. Click **Access > Access Device > Device > Search** to search the device on the software. When an appropriate server address and port are set on the device, the searched devices are displayed automatically.

The screenshot displays the 'Access / Access Device / Device' interface. At the top, there are input fields for 'Device Name', 'Serial Number', and 'IP Address'. Below these is a toolbar with icons for Refresh, New, Delete, Export, Search, Control, Set up, View / Get, and Communication. A 'Search' dialog box is open, showing a search bar and a table of results. The table has columns for IP Address, MAC Address, Subnet Mask, Gateway Add..., Serial Number, Device Type, Set Server, and Operation. One device is listed with IP 192.168.137.32. A red dashed box highlights the 'Add' button in the 'Operation' column, labeled 'Step 3'. An 'Add' dialog box is also open, with fields for 'Device Name*' (192.168.137.32), 'Icon Type*' (Door), 'Area*' (Area Name), and 'Add to Level'. A warning message states: '[Clear Data in the Device when Adding] will delete data in the device (except event record), please use with caution!'. The 'OK' button is highlighted with a red dashed box and labeled 'Step 4'. Other steps are indicated by green callouts: 'Step 1' points to the 'Search' button, and 'Step 2' points to the 'IP Address' field in the search dialog.

2. Click **Add** in an operation column, a new window will pop-up. Select Icon type, Area, and Add to Level from each dropdowns and click **OK** to add the device.
3. Click **Personnel > Person > New** and fill in all the required fields to register new users in the software.
4. Click **Access > Device > Control > Synchronize All Data to Devices** to synchronize all the data into the device including the new users.

For more details, please refer to the *ZKBio CVAccess User Manual*.

● Register on the Phone

Once the ZKBio CVAccess software is installed, the users could enroll their face template via a browser application on their own mobile phone.

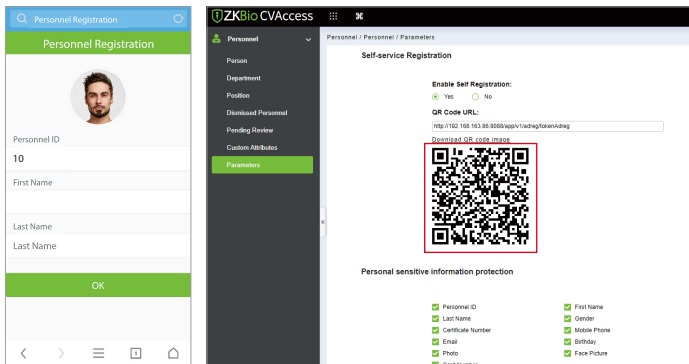

1. Click **Personnel > Parameters**, input "http://Server address:Port" in the QR Code URL. The software will automatically generate a QR code. To register users, scan the QR code or log in at 'http://ServerAddress:Port/app/v1/adreg' using a mobile phone.



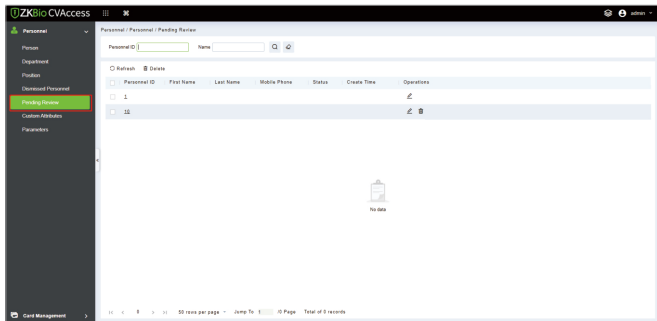

2. The users will be displayed in **Personnel > Pending Review**.



11 Ethernet and Cloud Server Settings

Click on  > **COMM.** > **Ethernet** to set the network parameters. If the TCP/IP communication of the device is successful, the icon  will be displayed in the upper right corner of the standby interface.

Click on  > **COMM.** > **Cloud Server Settings** to set the server address. If the device communicates with the server successfully, the icon  will be displayed in the upper right corner of the standby interface.

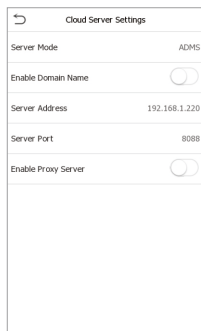
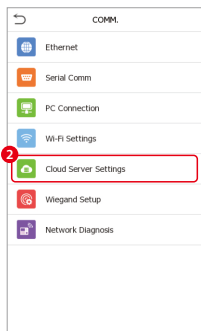
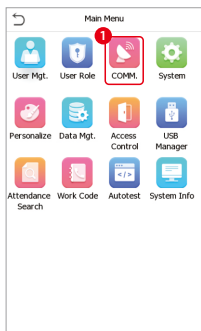
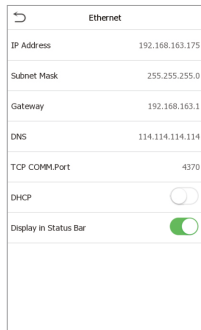
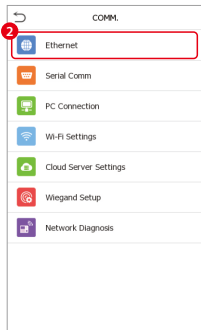
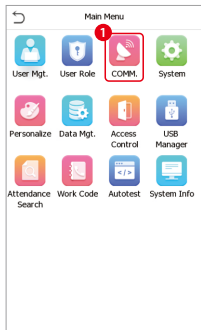

12 Connecting to ZKBio Zlink App

Click on ☰ > **System** > **Device Type Setting** to change the device communication protocol to the BEST protocol, the device can then be managed by ZKBio Zlink.

Step 1: Download the App

Search for the **ZKBio Zlink** App in Apple App Store or Google Play Store and download the App into your smartphone.



Step 2: Create Your Account

Open the **ZKBio Zlink** App and create an account with your phone number or an Email ID.

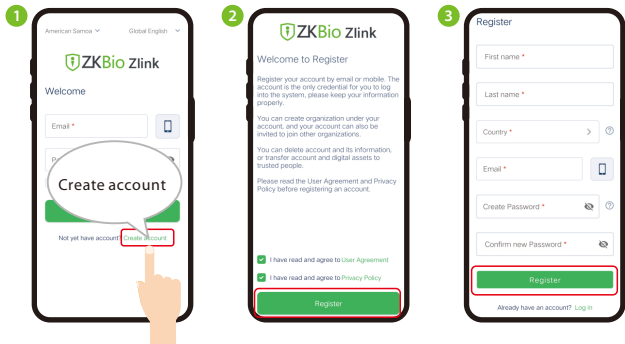

Step 3: Create the Organization

Log in with your successfully registered account and follow the page prompts to create an organization.

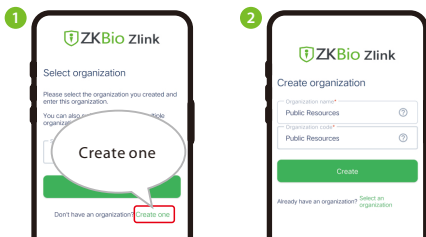

Step 4: Add the Site and Zone

Log in with your created account and organization. After a successful login, add **Site** and **Zone** in the **Me** interface.

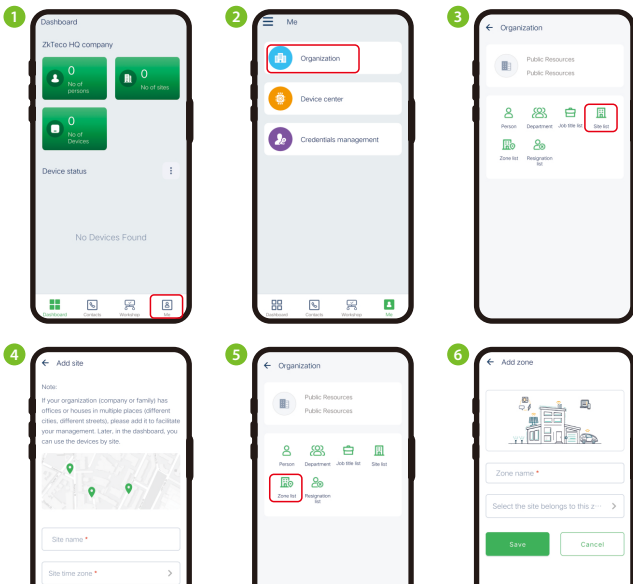

Step 5: Binding the Device

In Workshop interface, click CloudACC > Me > Device List to add devices.



13 Connecting to ZKBio Zlink Web

After successfully adding devices using the ZKBio Zlink App, you can use the created account to access the ZKBio Zlink Web. With this web interface, you can find devices, add new personnel, register verification methods for registered personnel, synchronize personnel to devices, and query records. To access the ZKBio Zlink Web, please visit <https://zlink.minervaiot.com/>.

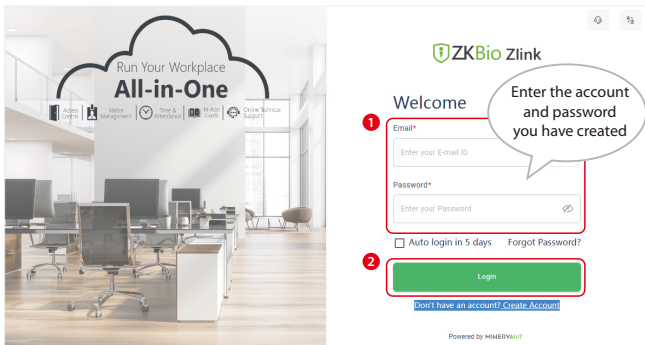

Add Person:

1. Click **Me > Organization** on the ZKBio Zlink Web main menu to add a person.

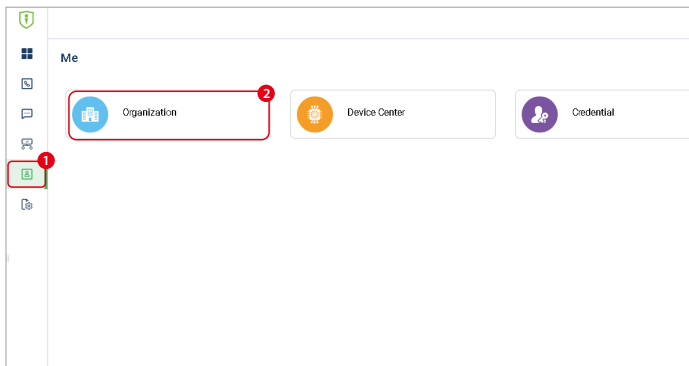

2. Click add icon  to add a new person. Enter the person's information, and click **Save**.

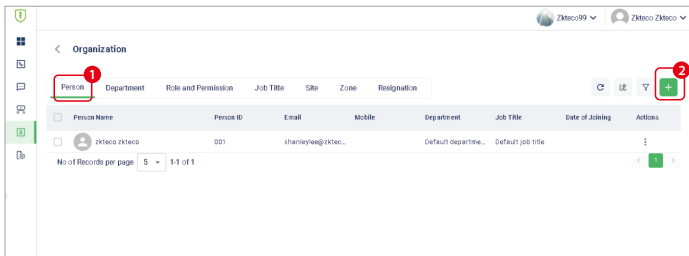

Synchronize Persons to Device:

1. Click **Workshop** > **CloudACC** on the ZKBio Zlink Web main menu.

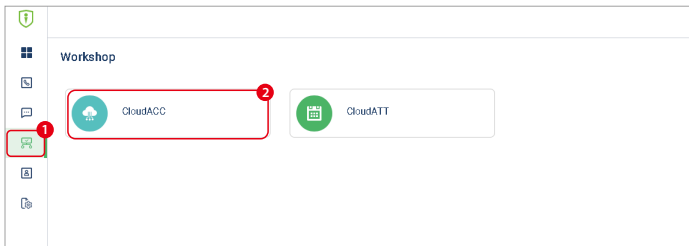

2. Click **Access Control** > **Group Access Time** > **Manage Door** icon  to choose the device.

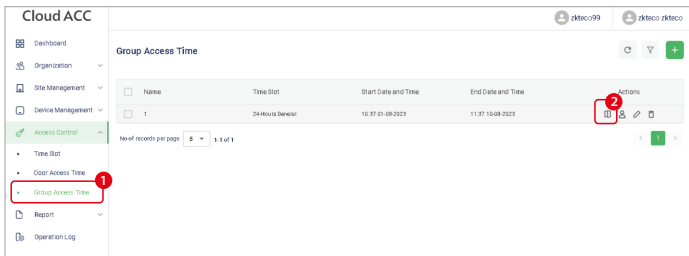

Cloud ACC zkteco99 zkteco zkteco

Manage Door

Door Name	Device Name	Device Serial Number	Door Number	Verification Mode	Actions
Door-1	SpecFace-V4L Pro	8957232340005	1		

No. of records per page: 5 1-1 of 1

3

Cloud ACC zkteco99 zkteco zkteco

Add Door

<input checked="" type="checkbox"/>	Door Name	Device Name	Device Serial Number	Door Number	Enable/Disable	Verification Mode
<input checked="" type="checkbox"/>	Door-1	SpecFace-V4L Pro	8957232340005	1	✓	

No. of records per page: 5 1-1 of 1

4



5

Add Clear

3. Click **Access Control > Group Access Time > Manage Person** icon  to choose persons for synchronization to this device.

Cloud ACC zkteco99 zkteco zkteco

Group Access Time

<input type="checkbox"/>	Name	Time Slot	Start Date and Time	End Date and Time	Actions
<input type="checkbox"/>	1	24-Hours General	10:37:01-08-2023	11:37:10-08-2023	 

No. of records per page: 5 1-1 of 1

2

1

Cloud ACC zkteco99 zkteco zkteco

Manage Person



First Name	Last Name	Person ID	Actions
Mike	Mike	1	

No. of records per page: 5 1-1 of 1

3

14 Connect the Wireless Doorbell★

This function needs to be used with the wireless doorbell.

First, power on the wireless doorbell. Then, press and hold the music button  for 1.5 seconds until the indicator flashes to indicate it's in pairing mode. After that, click on the BioFace B1 icon , if the wireless doorbell rings and the indicator flashes, it means the connection is successful.

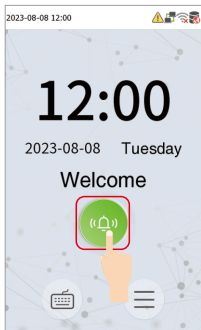

BioFace B1

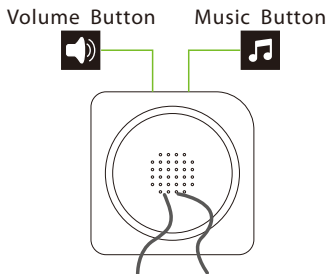

Wireless Doorbell

After a successful pairing, clicking the  icon of BioFace B1 will ring the wireless doorbell.

Note: Generally, each BioFace B1 connects to 1 wireless doorbell.

ZKTeco Middle East, Bay Square, Building 1,
Office 502 & 503, Business Bay, Dubai, UAE
Phone : +971 4 3927 649
www.zkteco.me

